

WORLD MARKET®

Assembly Instructions

Nylah Rattan 4 Shelf Bookcase

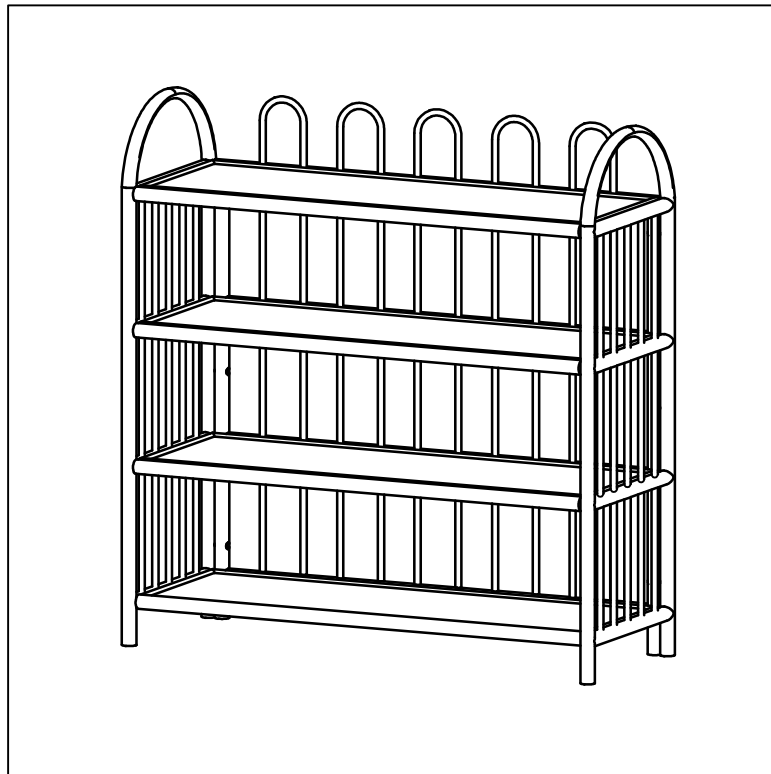

SKU-596350



THANK YOU FOR PURCHASE. IF YOU HAVE ANY QUESTIONS
PERTAINING TO THE ASSEMBLY OF THIS FURNITURE PIECE, PLEASE CONTACT
THE NEAREST WORLD MARKET STORE.
IF YOU ARE NOT NEAR A STORE, PLEASE CALL OUR CUSTOMER SERVICE CALL
CENTER TOLL FREE AT 877-967-5362 FOR ASSISTANCE.

All products sold at World Market
are not for commercial use and are
intended for residential use only.

Component List

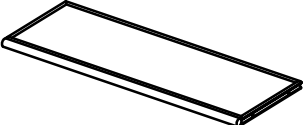
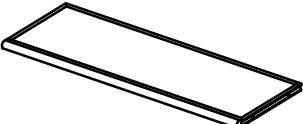
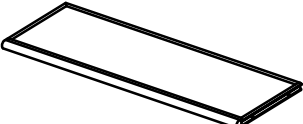
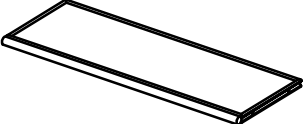
LABEL	PICTURE	DESCRIPTION	QTY
A		Back Frame	1
B		Right Side Frame	1
C		Left Side Frame	1
D1		Shelf Panel 1	1
D2		Shelf Panel 2	1
D3		Shelf Panel 3	1
D4		Shelf Panel 4	1

Hardware List

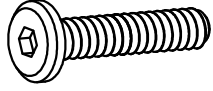
LABEL	PICTURE	DESCRIPTION	QTY
H-1	 A technical drawing of an Allen bolt, showing a hexagonal head and a threaded shaft.	Allen Bolt M6 x 40mm	30

Tool List

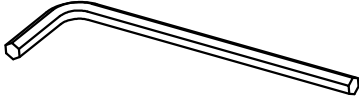
LABEL	PICTURE	DESCRIPTION	QTY
T-1	 A technical drawing of an Allen key, showing a long shaft with a hexagonal end.	Allen key	1

Assembly Preparation

Before Beginning :

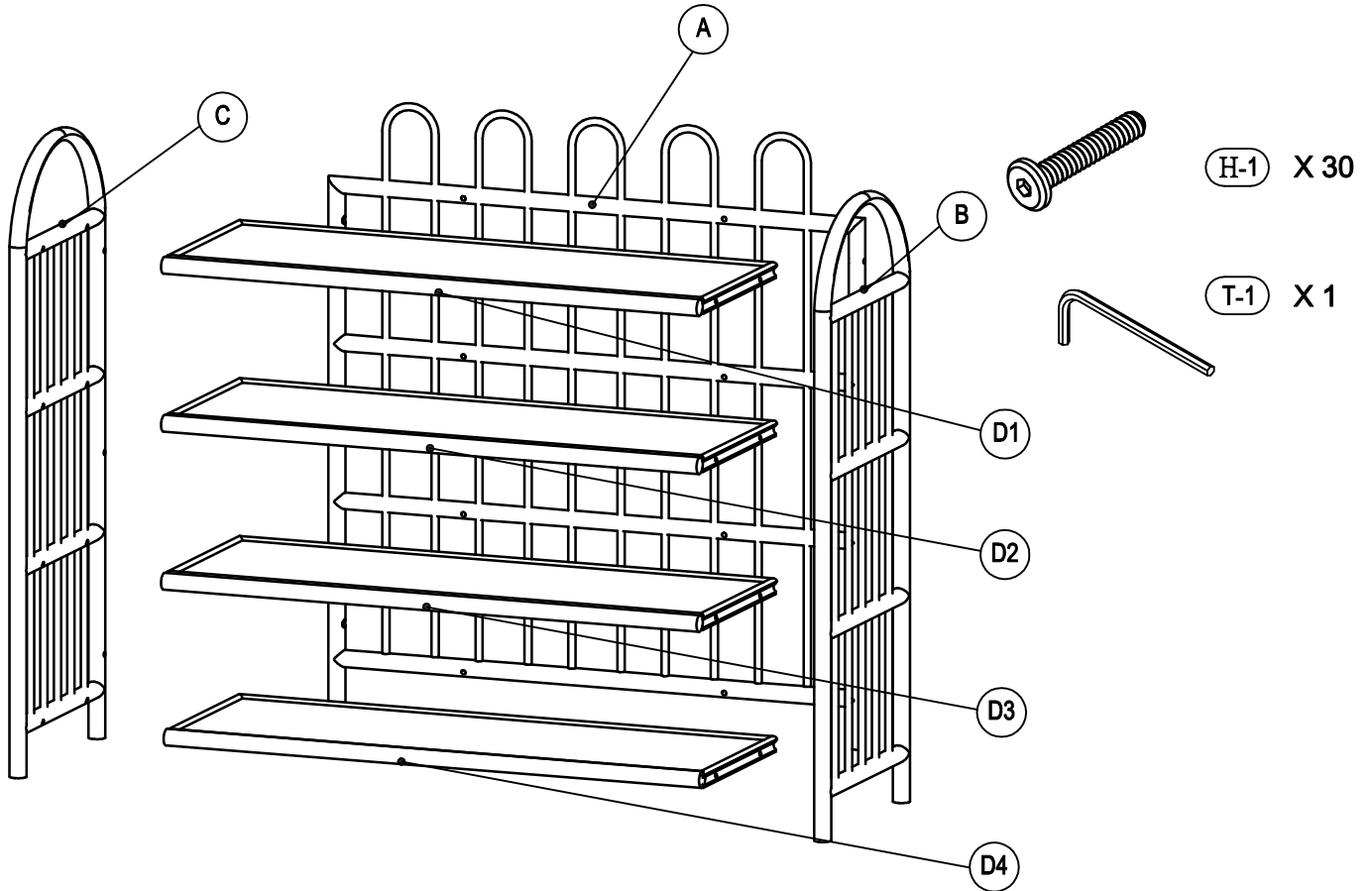

- Unpack all hardware bags and components to ensure you have all parts-



- Read instructions, cover to cover-



- Have 2 adults on hand for assembly-



- Do not assemble on flooring or carpet-



- Assemble on a clean non-marring surface (packing foam)-



- Save all packaging until finished-



- In case of missing parts, please contact your nearest World Market store or call our customer service call center at call 1-877-967-5362.

Assembly Steps

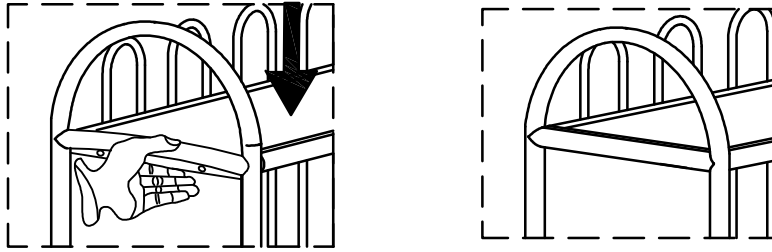

Due to the nature of the rattan material (flexible) we will sometimes need to press the component to align the holes during the assembling process

STEP 1 : Assembling Left Side Frame (C) and Back Frame (A)

 (H-1) Allen Bolt M6x40 x 3

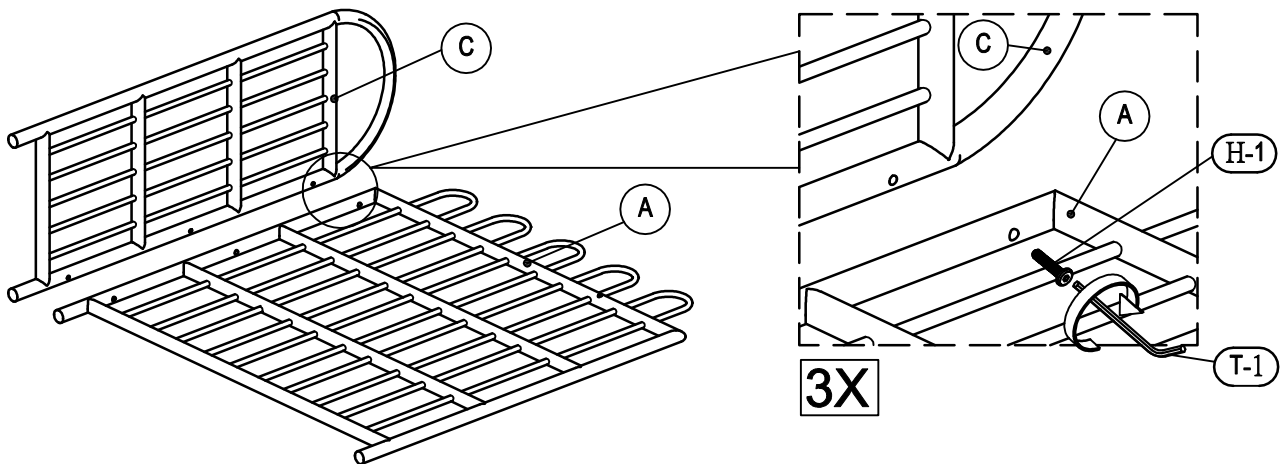

- Lay Back Frame (A) down onto a padded, non marring surface.
- Align holes on Left Side Frame (C) with the corresponding holes along Back Frame (A). Secure using Allen Bolts (H-1). Engage all Bolts by hand but **DO NOT fully tighten them yet.**

STEP 2 : Assembling Shelf Panel (D1), (D2), (D3), (D4)

 (H-1) Allen Bolt M6x40 x 16

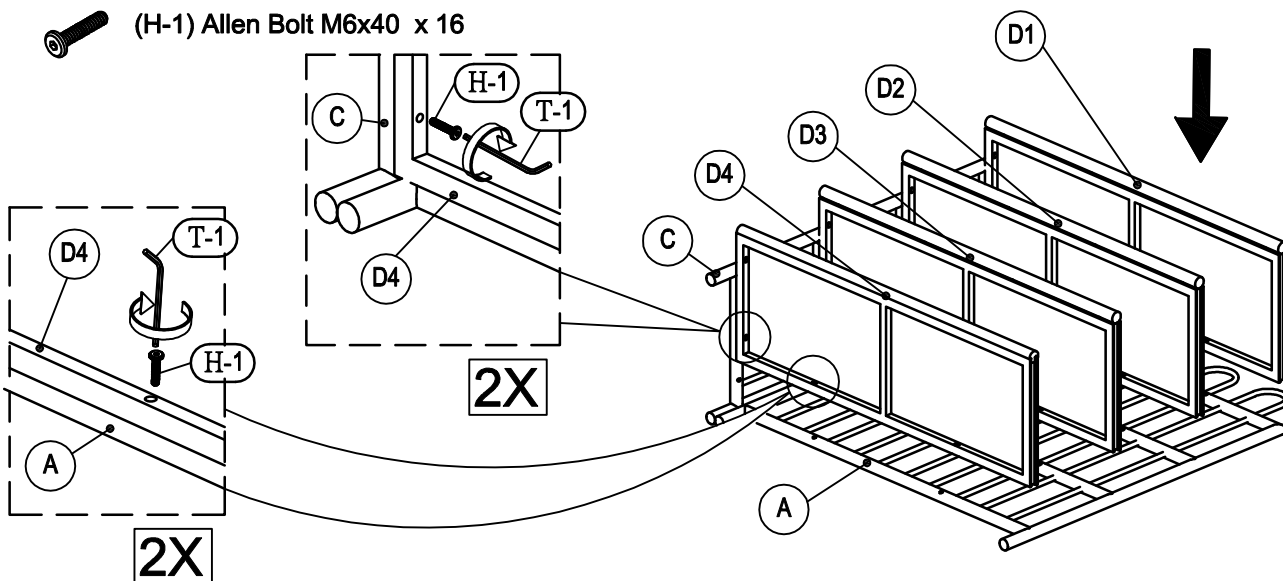

- Align holes on Shelf Panel (D4) with the corresponding holes along Back Frame (A). Secure using Allen Bolts (H-1). Engage all bolts by hand but **DO NOT fully tighten them yet.**
- Align holes on Shelf Panel (D4) with the corresponding holes along Left Side Frame (C). Secure using Allen Bolts (H-1). Engage all bolts by hand but **DO NOT fully tighten them yet.**
- Repeat the above step for the 3 remaining Shelf Panels (D1), (D2), (D3).

Assembly Steps

STEP 3 : Assembling Right Side Frame (B)

 (H-1) Allen Bolt M6x40 x 11

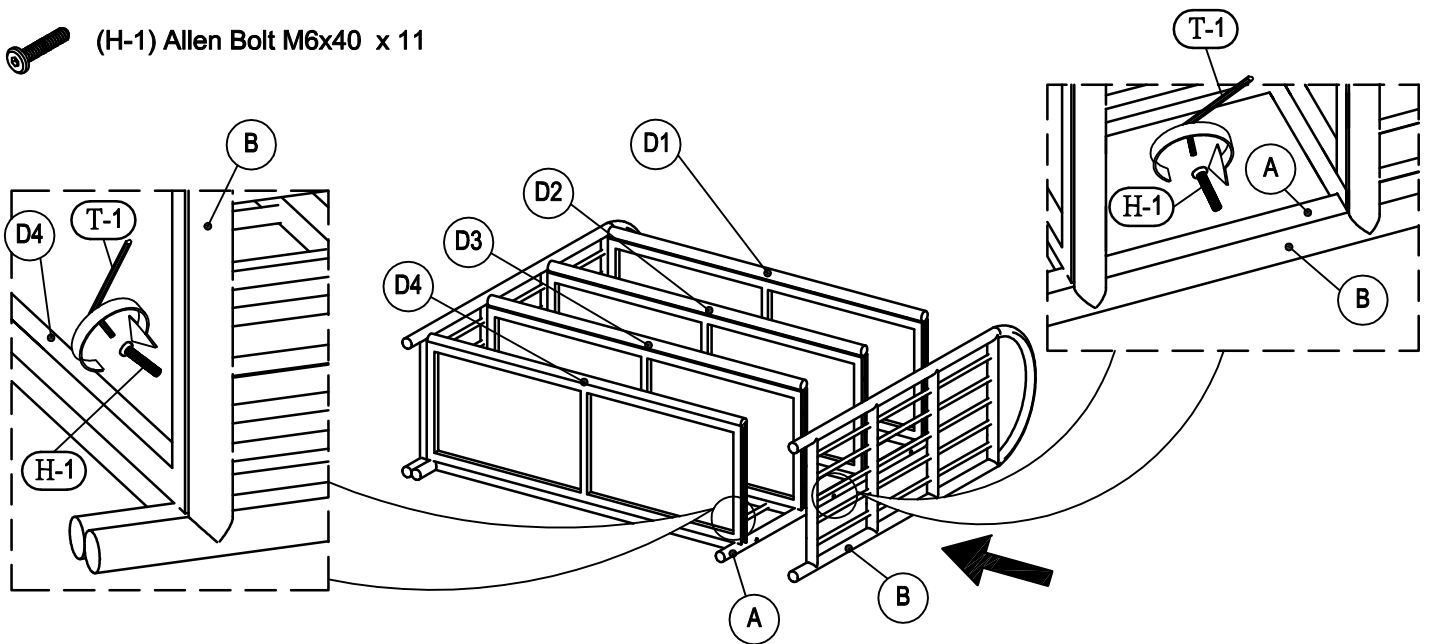

- Position Right Side Frame (B) into position as shown, aligning the holes with those on the side of Back Frame (A) and all corresponding holes on each Shelf Panel (D1), (D2), (D3), (D4) . Secure Right Side Frame (B) to the Shelves (D) and Back Frame (A) using Allen Bolts (H-1). Engage all bolts by hand but **DO NOT** fully tighten them yet.
- Once Right Frames (B) have been attached to the assembly, **FULLY TIGHTEN** all Allen Bolts (H-1) from Steps 1-3 at this time using Allen Key (T-1).

STEP 4 : Turn Upright

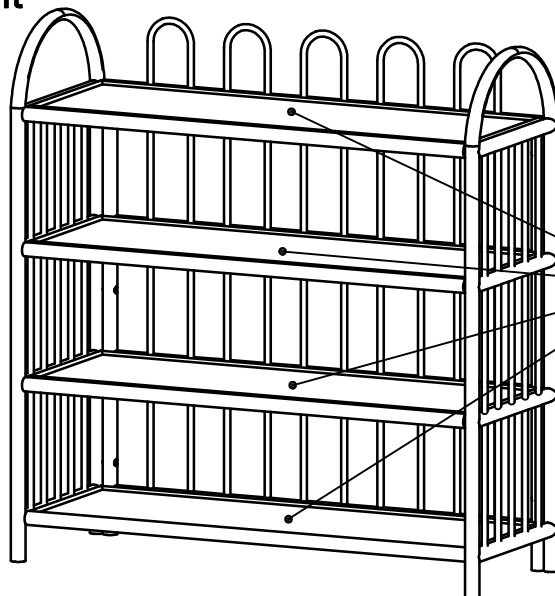

 **CAUTION**
MAX LOAD PER SHELF: 150 LBS

- Using a second person to assist you, carefully turn the assembly upright. Ensure it rests evenly on all four legs and that all bolts have been fully tightened at this time.
- Assembly is now complete and the product is ready for use.

Caution !
Maximum Load per Shelf: 150 Lbs

Care & Maintenance



- Do not put hot items directly on furniture surface.



- Do not clean furniture with harsh cleansers or polish.



- Do not place furniture near heating or cooling vents.



- Do not write on furniture without a padded barrier to protect the surface.



- Store furniture or use an appropriate furniture cover during cold or inclement weather.



- All products sold at World Market are not for commercial use and are intended for residential use only .



- Dust and pick-up spills using a clean, not-colored, lint-free cloth.



CAUTION
Maximum load per shelf is 150 lbs.

Anti Tip Kit

Assembly Instructions Enclosed

Disclaimer:

Warning - Children may be injured by tipping of furniture and the use of the Anti-Tip Kit is highly recommended.

This Anti-Tip Kit is only a deterrent. It is not a substitute for proper adult supervision. Manufacturer and retailer assume no liability for improper installation or excess loads placed on screws, brackets, or straps. When properly installed, this restraint provides protection against unexpected tipping of furniture. This Anti-Tip Kit **MUST** be installed into the wall using proper mounting hardware **OR** into a wall stud using appropriate screws. Position of the Anti-Tip Kit depends on the product and the location of the wall studs. The hardware provided is not a comprehensive solution for all wall types. Be sure to consult a professional or your local hardware store to determine the hardware needed for your specific wall type (plaster, drywall, concrete, etc.).

Installation Instructions:

Using a second person to assist you, place the unit in the desired final location against a wall. It is suggested to use a stud finder to find wall studs along the length of the unit and roughly 1 inch below the top shelf of the unit. Where possible, mark a drill hole position on the wall where there is a stud and use a drill or screwdriver (**NOT INCLUDED**) to attach wall Mounting Brackets to the wall using Long Screws in the location of the wall studs.

ANTI TIP KIT

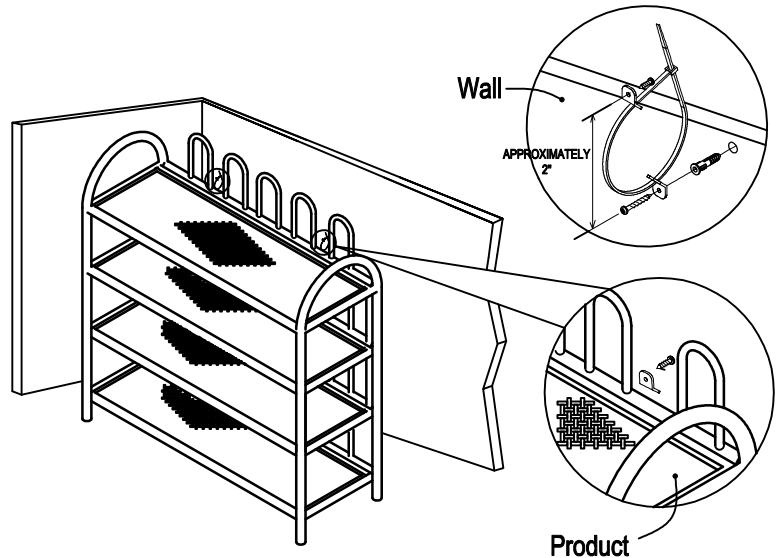
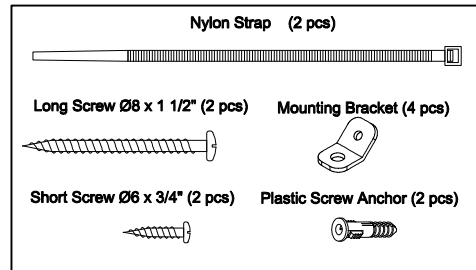

In a case where there is no wall stud, hold Mounting Brackets on wall and mark the drill hole positions so that they are roughly 1 inch below the top shelf of the piece. Using a drill with a drill bit roughly the diameter of the Plastic Screw Anchors, drill pilot holes in marked positions. Insert the plastic Screw Anchors into the holes until the tops are roughly flush with the wall. Align the holes and insert the Long Screws through Mounting Brackets and into the corresponding holes in the wall using a phillips head screwdriver (**NOT INCLUDED**).

Next, attach remaining 2 Mounting Brackets to the back of the piece using Short Screws so they align with Brackets installed on the wall. Loop Nylon Straps through Mounting Brackets on the furniture piece, then through Mounting Brackets on the wall and tighten until snug. Installation is now complete.

IMPORTANT: Check that the Mounting Brackets are firmly screwed into the wall and the Nylon Straps are snug.

If there is any hesitation, please consult a professional or your local hardware store.

WORLD MARKET LIMITED ONE-YEAR WARRANTY – Indoor Furniture

For your customer satisfaction, this product carries a LIMITED ONE-YEAR WARRANTY from the date of purchase. This limited warranty only applies to World Market brand furniture, and not to other furniture brands sold on World Market's website.

Where applicable, the limited warranty provides coverage for:

1. **Manufacturing, Material and Workmanship Defects:** Includes defects related to core frame/structure substrates (wood and metal); cracking, splitting, or complete breakage of hardwood, plywood or medium density fiberboard (MDF); cracking, splitting or lifting of wood veneer or laminated top surfaces caused by process failure; broken welds or improperly coated metal frame components (powder coating or painted); fabric or leather material defects including tears, misprints, fraying, crease marks, skip stitches or open seams; support webbing material and sinuous spring defects or damage, including method of attachment to frame; and other component failures that are a direct result of manufacturing or workmanship defects.
2. **Cushions & Cushions with Enclosed Steel Pocket Coils:** Failed or ruptured steel pocket coils enclosed inside of seat cushions, or loss of resiliency from a material breakdown of foam or fiber filling, which should not be confused with softening or settling during normal use.
3. **Leather:** Splitting or cracking of leather material. NOTE: The warranty does NOT cover natural hide markings, variations in the leather color or grain due to the authentic natural properties of processed cowhide leather.
4. **Bonded Leather or Bi-cast Leather:** Separation of the polyurethane coating, peeling or cracking of the inner layer or at the bonded seam edges (bi-cast straps).
5. **Furniture Components (Hardware & Mechanisms):** Includes defects to pre-installed components or hardware provided to the customer for assembly such as office chair hydraulic lifts, lift mechanisms, metal bases and casters, swivel plate mechanisms; for drawers, metal glides, handles/knobs; for doors, hinges, magnetic latches; and other components such as bent or stripped threaded leg posts and adjustable levelers. For missing, damaged, corroded, or misplaced hardware components such as bolts or washers, please contact Customer Service at: 877-967-5362.

This LIMITED ONE-YEAR WARRANTY does NOT cover:

1. Damage due to mishandling during transportation from store or transportation without original protective packaging.
2. Abuse, negligence (product misuse) or wear and tear that may result in or from:
 - a. **Wood & Veneer:** Mishandling, exposure to moisture, peeling or discoloration caused by exposure to moisture or excessive sunlight, heat; splintered, dented or nicked panels, legs or component edges or paint/finish blemishes; or treatment with corrosive chemicals (dyes, inks, paints or harsh cleaning products).
 - b. **Fabric & Leather (Including Bonded or Bi-Cast Leathers):** cuts, punctures, tears, burns, pet damage, or treatment with corrosive chemicals (dyes, inks, paints or harsh cleaning products), exposure to direct sunlight, fire, high heat, water, or any bright light source (natural or artificial) that may cause splitting, peeling or flaking with time.
 - c. **Foam (Cushions):** Flattening, relaxing or settling/softening of foam components that comes with normal use.
 - d. **Hardware Components:** improper installation or misuse/substitution of hardware components not defined in the Assembly Instructions for the product (if applicable)
3. Damage due to environmental exposure to direct sunlight, fire, high heat, water or extreme humidity, any bright light source (natural or artificial), or any environment that the product is not intended for.
4. This warranty is applicable for indoor furniture products purchased for residential use only.

For additional information on returns, please visit: <https://www.worldmarket.com/category/customer-service/returns.do>

All products sold at World Market are NOT FOR COMMERCIAL USE and are intended for residential use only. Products purchased for commercial use will VOID all warranty provisions as listed above.

Any claims under this LIMITED ONE-YEAR WARRANTY are valid and applicable only as to the original purchaser and must be accompanied by proof of purchase. Warranty claims should be submitted to a World Market store or through World Market Customer Service Call Center, Toll Free at 877-967-5362.

For valid warranty claims, World Market will repair or replace the product, or offer a full or partial credit, in the sole discretion of World Market. This LIMITED ONE-YEAR WARRANTY gives you specific legal rights and you may also have other rights which vary from state to state.